

# greasemaster3

**Greasemaster3** is purposely designed to provide grease to single line progressive distribution systems.

Grease is delivered through a unique filtration process which protects the system it feeds from contamination. Robust construction and heavy-duty pump station to power automatic grease systems on machines working in tough environments.

Grease up to NLGI 2\*\* are delivered to bearings in pre-determined ratios by means of **blocmaster** distribution blocks Blocmaster : <http://www.bignall.co.uk/masterlube/blocmaster.asp> .

**Greasemaster3** may be filled by standard (54mm Dia.) grease cartridge or by hand grease gun.

## SPECIFICATION

Weight (Empty)	6.2Kg
Capacity	5Ltrs Nominal
Grease Specification**	Lithium NLGI 2**
Voltage	12v/24v dc Polarity Protected
Current	2A Max
Output Pressure	Adjustable up to 200bar***
Delivery	12v ~ 2.5cc / 24v ~ 6.0cc
Temperature Range	+40°C / -15°C
Filling	Grease Nipple / Cartridge Fill

## NOTE

- \*All tests carried out at ambient temp. to air
- \*\* <http://www.bignall.co.uk/masterlube/grease-recommendations.asp>
- \*\*\* Do not operate pump without 190 or 200 Bar pressure relief valve

On receiving the pump, fill the reservoir to within 15mm / ¾" of the top of the reservoir tube with good quality grade II lithium base grease\*\*.

Connect the pump to a suitable power supply using suitable cable (**RED - POSITIVE +ve /BLACK - NEGATIVE -ve**). Ensure specification of cable is sufficient to prevent voltage loss along its length.

## MAINTENANCE

Fill the grease pump regularly and avoid long periods of running the pump empty. *Do not overfill*. Keep the reservoir tube clean on the outside so that levels can be observed. Clean the filter every 2500 hours of machine (not pump) operation. If contamination is noted, this period should be altered accordingly

## Filter Maintenance

1. Remove filter cartridge from base using a 1" A/F open ended Spanner / Adjustable Spanner
2. Unscrew Retaining Ring, remove GM3 Filter.
3. Wash the filter in a suitable solvent/Paraffin Bath and blow away any remaining debris if necessary. Replace the filter mesh if it is damaged with Part No. GM3 FILTER
4. Refit GM3 Filter.
5. Screw Retaining Ring onto housing. Ensure that the Retaining Ring is in correct position (See Diagram below.)
6. Refit Filter, *Do Not Over tighten*

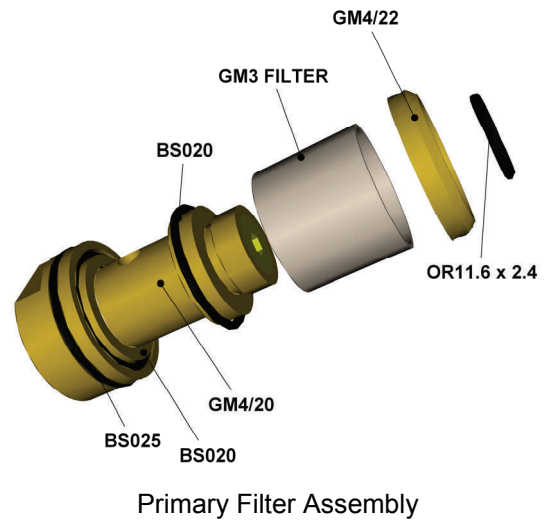

Correct Fitting of Retaining Ring  
Retaining Ring GM4/22  
Flush With GM4/20 Body

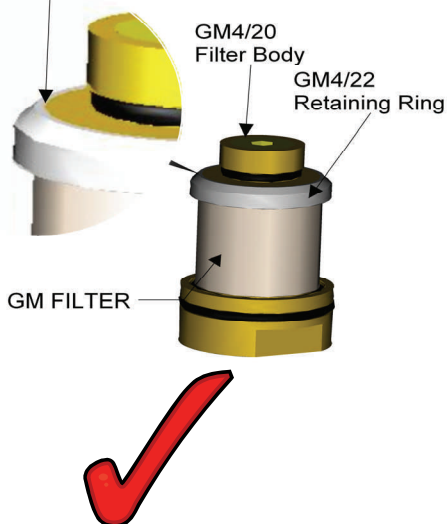

Incorrect Fitting of Retaining Ring

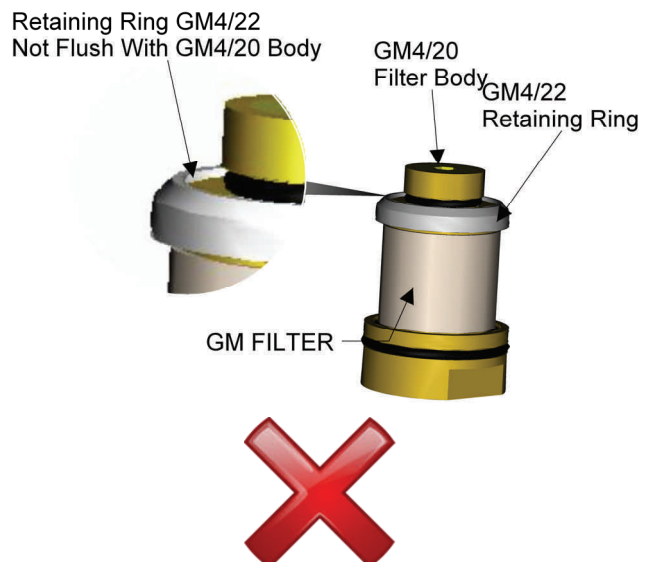

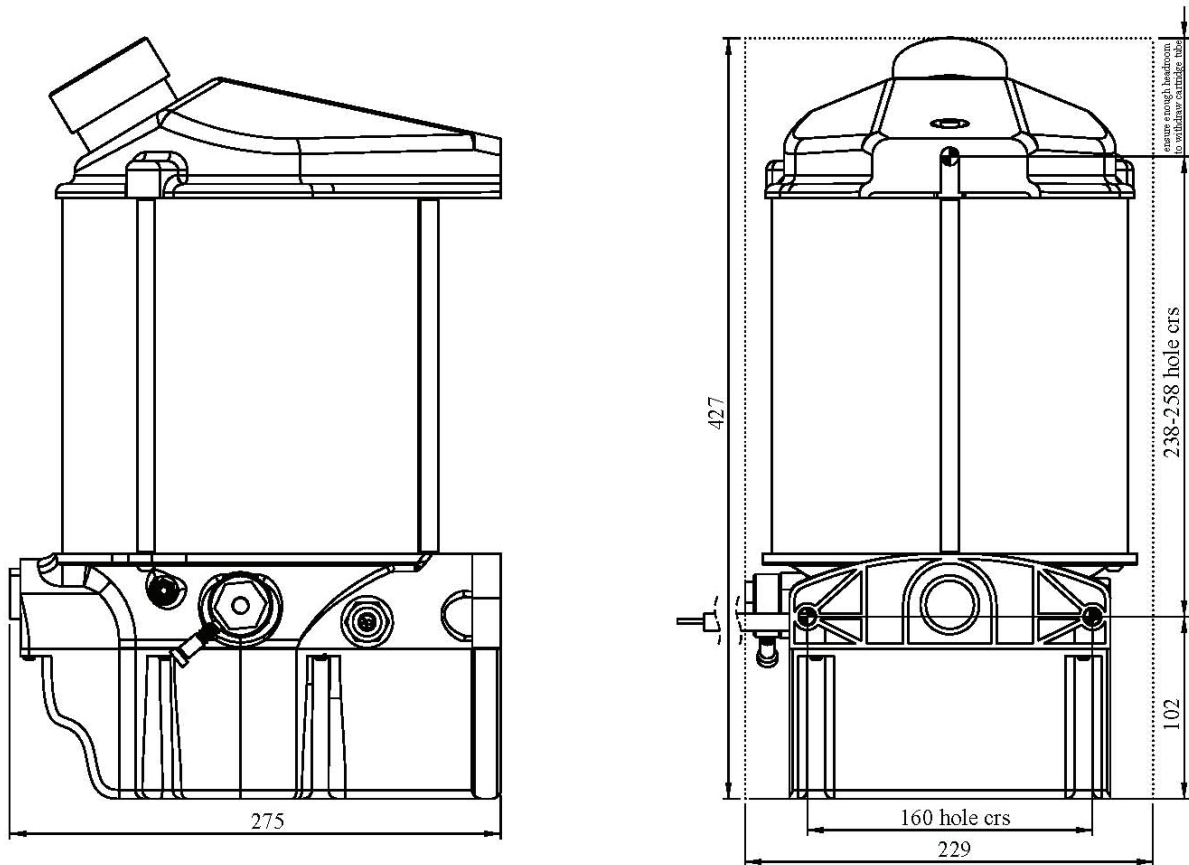

### Spares Parts

Code	Description	Code	Description
9900278	12/24 v Motor Unit	GM4/12	GM3 Motor Cover
BLANK PLUG	GM3 Blank plug	GM4/16	GM3 impellor assembly
BS264	Reservoir O-ring	GM4/22	GM3 FILTER retaining ring
GM3 FILTER	GM3 FILTER Mesh	GM4/30	GM3 FILTER Cartridge assembly
GM3/10	Reservoir Pillar Rods (5 ltr) (3 per kit)	GRM/PE	GM3 pump element assembly
GM3/18	5 ltr Reservoir	PRV190	Pressure Regulator Valve @ 190 BAR
GM3/28	GM3 Lid assembly complete	PRV200	Pressure Regulator Valve @ 200 BAR
GM3/29	Grease cartridge filler rod assembly		
GM3/32	Banjo Bolt Assembly		

## OPERATING THE PUMP

The pump is designed to be controlled by a timing device, which has a set duty cycle according to grease requirements of the system. There are two timer settings:

- 2.5 minutes ON cycle / 2.5 minutes OFF cycle
- 4 minutes ON cycle / 1 minutes OFF cycle

The timer has been set at the factory in accordance to order/grease requirements. This can be altered to suit individual requirements.

There will be three leads coming from the timer (blue circuit board).

Black – Negative

Thick Red – Positive for 2.5mins ON / 2.5mins OFF

Thick & Thin Red – Positive for 4mins ON / 1min OFF

To set for 2.5mins ON / 2.5mins OFF only wire up one black and thick red lead.

To set for 4mins ON / 1min OFF connect the two red leads together and wire up as normal.

Green – To terminal block as shown

Red – To terminal block as shown

Once mounted and connected to a suitable supply, fill the pump with grease (see grease spec) and let it run. If the pump is already primed with grease it will start delivering. (Primed pumps are always primed with lithium-based grease.) Empty pumps will self-bleed and will take some minutes to do so.

## SELECTING A SUITABLE GREASE

Greasemaster 3 (GB) will pump most good quality greases of grade NGLI 0 to NGLI 2. The initial factory fill will be of NGLI grade 2 grease with a lithium base. The mixture of greases, particularly those of dissimilar base such as calcium and lithium can cause a breakdown of the oil suspension in the grease. Note that many greases have a shelf life of only 18 months. Consult your supplier about other greases. For further information please read the recommendations on our website

<http://www.bignall.co.uk/masterlube/grease-recommendations.asp>

## GREASE SEPARATION

This occurs when the oil suspended in the soap base separates out leaving just the soap base. This will display itself as a wax like substance, which will clog both the filtration and distribution blocks within a system. Greasemaster 3 (GB) has a unique filtration system. Grease separation is most likely to show in the filter. The filter should be carefully cleaned and cause rectified.

Separation will be due to one of the following causes:

- Adding incompatible grease
- Using poorly mixed unstable or poor quality grease
- Forcing grease through a partly blocked filter mesh
- Grease being left in the system over the winter period

**To ensure that the system functions correctly it is important to operate the system frequently especially during the downtime period of the machine.**

## BLOCMASTER

### SYSTEM PRINCIPLE

The principle of progressive distribution is that each point is fed in turn, progressively through the system. Each block wafer has a piston, which delivers grease to a bearing in predetermined ratios. In this way larger bearings are fed with a greater proportion of the available grease.

Each piston delivers in turn within the block, delivering its grease to the outlet port and also allowing pressure to act on its neighbour, which in then delivers grease and so on. The process continues down one side of the block and then the other. Each piston **MUST** therefore deliver for the cycle to continue.

Each of the distribution blocks is fitted with a cycle indicator pin. This pin moves in and out of the block as a visual confirmation that the block is cycling.

### CARE AND MAINTENANCE

#### CARE MUST BE TAKEN TO USE ONLY CLEAN GREASE

Avoid refilling grease gun from open containers and ensure all nipples/zerks are clean and free of dirt.

Examine all Pipework regularly to ensure there is no damage. If a pipe is damaged, replace the pipe as soon as practical but **NEVER** blank off the outlet, as this will stall the block. Grease released from open outlet due to damaged Pipework will not affect the amount delivered to other points.

If points appear dry then disconnect and clear any blockage by greasing manually. Check that the Pipework is not damaged.

Check the underside of the pump to ensure drain holes are not blocked.

**NOTE:** Larger bearings and those close to crop may appear dry but can still be adequately lubricated inside. If this is the case, low back pressure will result, and the expelled grease will not be discoloured.

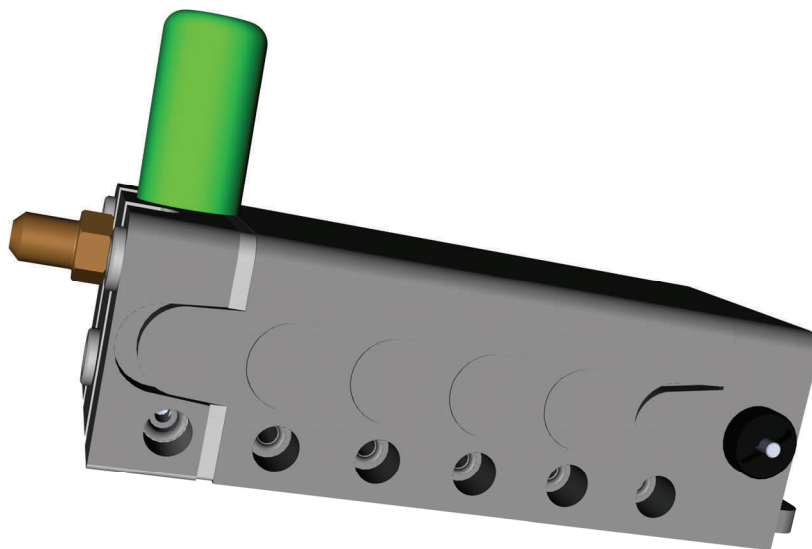

IF UNDER LUBRICATION OR ANY OTHER PROBLEMS PERSIST CONSULT WITH YOUR NEAREST DEALER.

**Note: Information and contacts are available on our website**

[www.bignall.co.uk](http://www.bignall.co.uk)

## TROUBLE SHOOTING GUIDE

**Fault:** Pump operates, but no grease is delivered

**Probable Causes:**

- Reservoir Level Low ..... Fill With Grease
- Secondary Filters Blocked (Grease May Show At Relief Port On LHS Of Filter Housing) ..... Remove Filters And Clean. Clean Reservoir And Fill With Clean Grease.
- Primary Filter Blocked (Indicator Pin May Not Be Moving Or Moving Only Slightly) ..... Remove Filter And Clean. Check For Debris At Inlet Inside Reservoir. Clean Reservoir And Fill With Clean Grease.
- Pump Element Non Return Valve Has Failed Or Come Loose..... Remove, Clean And Reassemble With New Parts As Required.
- Reservoir Contains Grease That Is Too Heavy. Max. NGLI Grade 2 Grease Recommended, Grade 1 For 0°C And Below ..... Remove Incorrect Grease And Replace With Recommended Grade.

**Fault:** Pump Operates, But Grease Comes Out Of Pressure Regulator Valve On Element. (On No Account Try To Reset The Valve To A High Pressure, The Valve Is There To Protect The System And Warn Of Faults. Overriding The Valve Will Not Cure The Fault.)

**Probable Causes:**

- One Of The Distribution Blocks Has Seized. This May Be Due To Contaminants Entering The System During Assembly, Repair Or A Failed Filter. Another Cause Maybe Separation Of The Grease Itself. Certain Poorly Mixed Greases Or Poor Quality Greases May Separate Out When Forced Through Drillings In The Blocks Leaving The Solid Soap Base Blocking Ports. This Separation May Also Be Caused By Mixing Incompatible Greases (E.G. Calcium And Lithium Base Greases) ..... Blocks Are Unsuitable For Servicing By The Customer And Should Be Replaced Or Returned To Masterlube Systems Ltd For Rework
- One Of The Bearings Supplied By The System Has Become Blocked (Possibly After Being Immobile For Sometime). Where This Is The Cause, The Pump May Operate For Some Hours Before The Back Pressure Builds To A Point Where It Opens The Pressure Relief Valve ..... Locate The Blocked Point By Looking For Dry Points And Seeing If The System Starts Again When The Point Is Disconnected. The Point Must Be Freed Before Reconnection To The System.
- The Master Block May Have An Individual Non Return Valve For Each Outlet. If These Seize The System Will Stall ..... Remove Each And Check In Turn. Free Off Or Replace.

**Fault:** The Timer Cycles But The Pump Does Not Operate The Pump.

**Probable Causes:**

- The Fuse In The Timer Has Blown ..... Check And Rectify Any Short Circuit And Replace Fuse
- The Cable To The Pump Has Been Damaged ..... Replace
- The Pump Has Been Disconnected And Rewired With The Incorrect Polarity ..... Reverse The Polarity
- The Pump Has Seized Causing The Re settable Fuse To Operate ..... Locate The Reason For Seizure And Solve. Remove Power To Reset Fuse And Reconnect.
- Re Settable Fuse Or Diode Have Failed ..... These Protect The Pump From Reverse Polarity And Motor Burn Out And Are Located Inside The Motor Cover. Test And Replace If Necessary.
- Motor Has Failed ..... The Pump Is Not Suitable For Customer Servicing And Should Be Replaced Or Returned To Masterlube Systems Ltd For Rework.

## TOOLS REQUIRED FOR FITMENT

- 1 Set Of Combination Spanners 8mm – 15mm
- 2 Pairs Of 7" Pliers
- 1 x 6" Mole grips
- 1 Set 3/8" Drive Socket Set
- 1 Pair Of Double Edged Snips (For Cutting Hoses Square)
- Slotted & Cross-Head Screwdrivers
- Electricians Screw Driver
- Electric Drill & Selection Of Drill Bits
- 32mm Open Ended Spanner
- 28mm Open Ended Spanner
- 1" (25.4mm) Open Ended Spanner

