

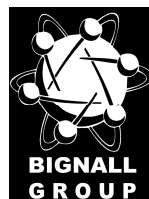

Greasemaster

Compac 3

Operations Manual

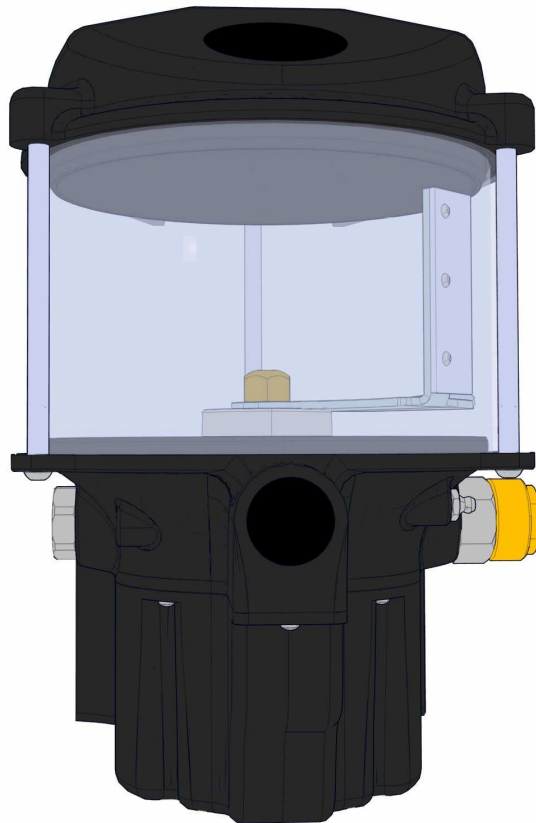

Unit 15, Dabble Duck Ind. Est., Shildon, Co. Durham DL4 2QN

Tel +44 (0) 1388 775584 Fax. +44 (0) 1388 778893

Email: post@bignall.co.uk Web: www.bignall.co.uk

Ref: GMC3 Iss 3 DEC 2009

SPECIFICATION FOR 12v

Weight (Empty)	5kg
Capacity	2kg Nominal
Grease Specification	Lithium NLGI 2
Voltage	12v dc
Output Power	3.3w Starting Torque 15nm @ 24v
Current Max	2.5a max.
Speed	12v : 18rpm APPROX
Output Pressure	200bar
Delivery Per Revolution	0.2cc +/- 10%
Delivery Per Minute	3.5cc +/- 10% .
Temperature Range	+40°C / -15°C
Direction Of Rotation	Clockwise
Filling	Grease Nipple

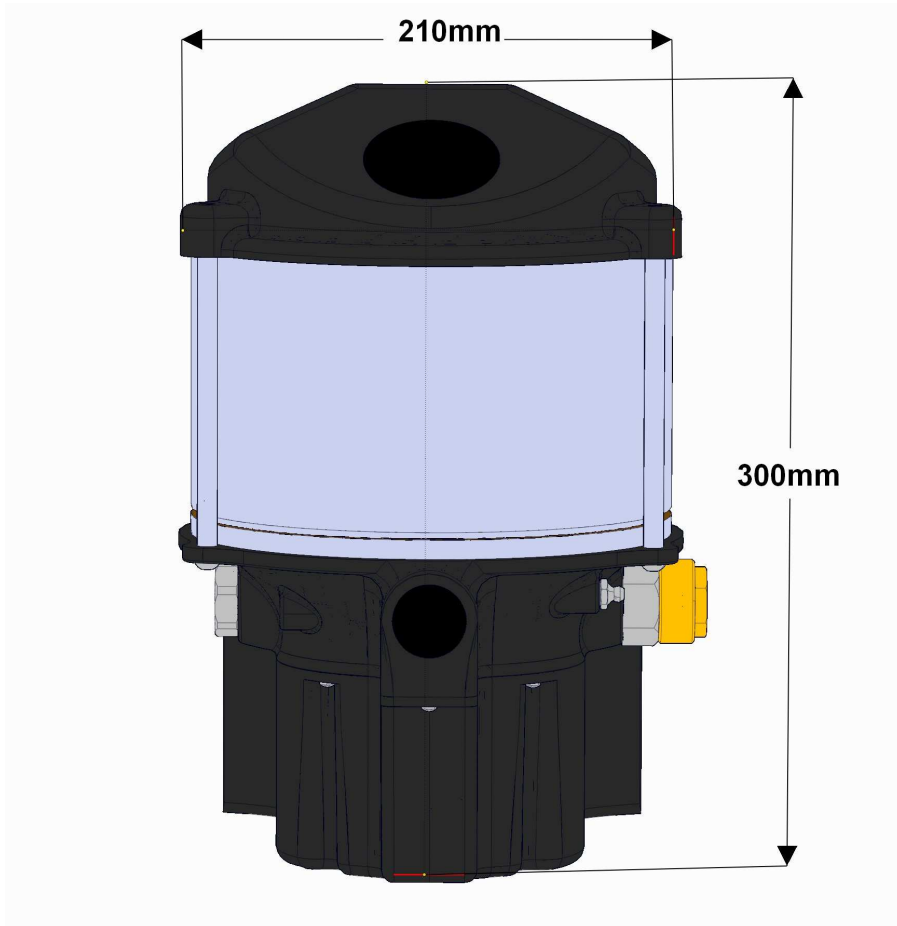
**GENERAL OVERALL DIMENSIONS**

GENERAL PRINCIPLE OF OPERATION

Greasemaster Compac 3 is designed as a simple but rugged pump, The carcass has two ports for up to two elements if required.

Circuitry can be added to provide a facility for adjustment without having to access the electronics. The circuitry is resin dipped to prevent damp or corrosion affecting the components.

An integral impellor agitates the grease to keep it fluid, wipes the reservoir glass and ensures the lower carcass does not cavitate.

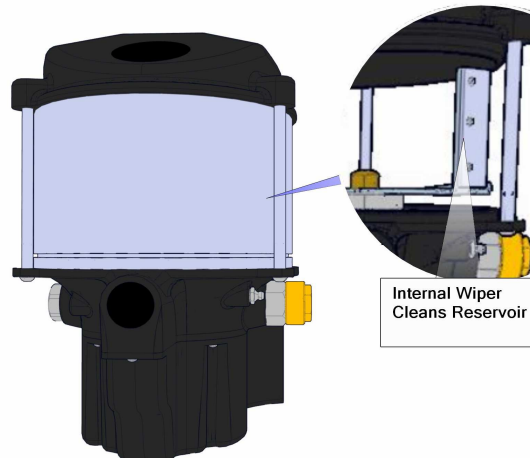

FILLING

As standard an 1/8" port is situated on the left or right hand side of the carcass and the pump should only be filled from this point. An 1/8" BSP hydraulic nipple is fitted from the factory. This can be replaced with quick release attachments but any such attachment should be self-sealing.

OVERFILLING

Overfilling of the reservoir should be avoided as pressure may build up in the reservoir and damage it. The pump should not be filled higher than 15mm / 3/4" from the top of the reservoir tube.

MOUNTING THE PUMP

The pump should be mounted using the two holes provided in the moulding and through bolted with M8 bolts. It should be mounted to a solid flat surface in an upright position using the two M8 bolt holes provided. A third mounting point is provided in the lid. This should always be used to steady the pump against vibration. If the application is exceptionally rough with heavy vibration the pump should be mounted on a plate with rubber mounts insulating the pump from the main structure.

WIRING AND CONNECTING THE PUMP TO A SYSTEM

Connect to a suitable power supply using a suitable cable (RED is POSITIVE +ve / BLACK is NEGATIVE – ve). Ensure cross section of cable is sufficient to prevent voltage loss along its length. The pump is polarity protected and will not work if polarity is not observed.

The pump outlet (1/8" BSP) must be connected to the master block with high-pressure hose or metal tube. Narrow bore hoses and softer flexible hoses can create significant pressure losses, particularly in lengths of over 2 metres. If in doubt contact your supplier.

OPERATING THE PUMP

Once mounted and connected to a suitable supply, fill the pump with grease (see Grease Recommendations page 6) and let it run continuously. If the pump is already primed with grease it will start delivering. (Primed pumps are always primed with lithium-based grease. If calcium or any other base grease is to be used the pump must be emptied and purged.) Empty pumps will self-bleed and will take some minutes to do so. (approx 30 minutes)

The pump can be designed to be controlled by a timing device, which will vary its duty cycle according to grease requirements of the system. Remote and integral timers are available that can be connected to offer optional warning systems to monitor system function. Full timer specifications are available from your supplier.

MAINTENANCE

Fill the grease pump regularly and avoid long periods of running the pump empty. Do not overfill (see filling).

SELECTING A SUITABLE GREASE (Also See Page 6)

Greasemaster Compac 3 will pump most good quality greases of grade NGLI 0 to NGLI 2. The initial factory fill will be of NGLI grade 2 grease with a lithium base. The mixture of greases, particularly those of dissimilar base such as calcium and lithium can cause a breakdown of the oil suspension in the grease. Note that many greases have a shelf life of only 18 months. Consult your supplier about other greases.

FILTRATION: WARNING AND CLEANING

Greasemaster Compac 3 has no internal grease filtration and great care must be taken when filling. The majority of systems failures occur as a result of the entry of contaminants into the system, usually during filling.

PRESSURE REGULATOR

Greasemaster Compac 3 is fitted with a pressure safety valve and is set to 200 bar; other settings are available to suit a particular application available upon request.

The pressure regulator is not fitted to the pump on despatch, it can be found in a small bag attached to the pump, the pressure regulator should be fitted to the Banjo body before the pump is started.

When fitting the pressure regulator be careful not to over tighten. Do not tamper with the setting of the regulator. When the pump is in operation no grease should be visible from the pressure regulator, if grease does appear investigate the system for blockages ect...

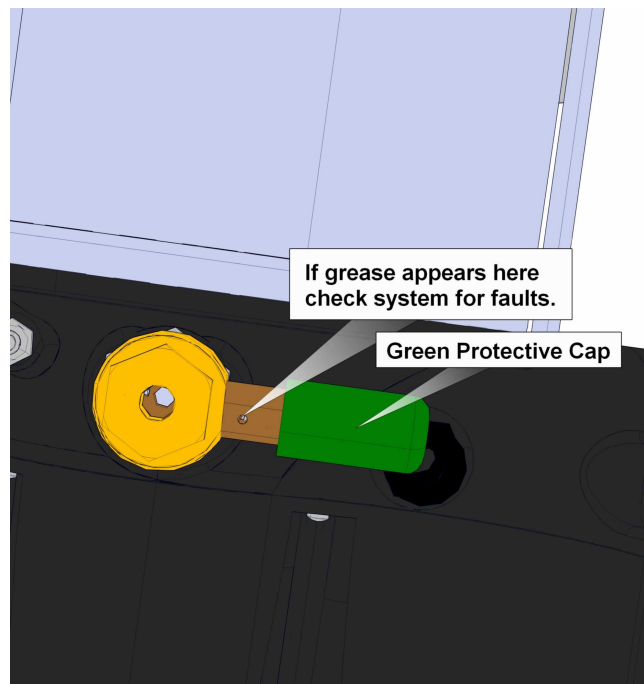

HEALTH AND SAFETY

The pump and system can deliver an output pressure of 200 Bar (2 900 PSIG).

FIRST AID MEASURES : Lithium NLGI2 Grease.

TYPES OF EXPOSURE	FIRST AID MEASURES
Ingestion Harmless if swallowed in small amounts – larger quantities may cause nausea and diarrhoea.	Wash mouth out with water. Do not induce vomiting because of the danger of choking. If choking occurs or is expected get immediate medical advice.
Skin May cause irritation, but prolonged or frequent contact could result in dermatitis.	Wash skin as soon as possible with soap and water. Change contaminated clothing and launder before reuse.
Eyes Likely to cause irritation with short-term redness and stinging.	Wash out thoroughly with water. If redness and/or irritation continues, get medical advice.
Inhalation Unlikely to be an irritant.	If inhalation of fumes irritates the nose or throat or causes coughing remove to fresh air. Get medical advice if irritation continues.

FIRE-FIGHTING MEASURES

Extinguish with dry powder, foam, sand or earth. For small fires use CO₂.

Do not tackle fires with water. Water may be used to cool the area surrounding fires.

Fires in closed or confined spaces should be tackled by trained personnel who should wear breathing apparatus.

ACCIDENTAL RELEASE MEASURES

May cause slippery surfaces.

Contain spillage – do not wash spillage down drain. Absorb using absorbent clay, sand or other suitable absorbent material. Report any escape to public drainage or watercourses to the Local Authority and Fire Brigade.

TOXICOLOGICAL INFORMATION

The mineral oils and other components of these oils may be considered not to be essentially toxic in normal handling.

ECOLOGICAL INFORMATION

In this environment these greases are likely to biodegrade slowly.

OTHER INFORMATION

Further information can be found in Health and Safety Executive Publications, a list of which may be made available on request.

Liability

The information contained in this data is accurate to the best of MASTERLUBE SYSTEMS Limited or its subsidiaries. The customer is strongly advised to observe and ensure that its employees and customers observe all directions contained herein. However, neither MASTERLUBE SYSTEMS Limited nor its subsidiary companies accepts any liability whatsoever arising out of the use of the information or the use adaptation or processing of the products designated herein.

Where third party products are used in conjunction with or instead of products produced or supplied by MASTERLUBE SYSTEMS Limited or its subsidiary companies, the customer should obtain all necessary technical, health and safety information about such products themselves from the third party.

GREASE RECOMMENDATIONS

All Masterlube Greasemaster range of pumps are designed to operate with Lithium base NGLI grade 2 greases.

These greases make up 70% of the current grease market.

Occasionally equipment manufacturers may recommend other greases for special reasons. Often this can be simply for the longer life properties. Where an automatic system is in use, clearly this requirement is already taken care of, however before reverting to a simple Lithium grade 2 grease the operator should check with the manufacturer to make sure the specification is not for the reason of other considerations such as shock loading, water ingress, heat etc.

Masterlube Greasemaster pumps will also pump other greases of NGLI grade 2 consistency, however when using these, the following points should be noted:

1. Although most of the more common grease bases will mix with our recommendation, (with the notable exception of Calcium), it is always advised to flush out the system before changing.
2. Lithium Complex and Lithium/Calcium Complex greases, although meeting NGLI grade 2 specifications, will be between 2 and five times harder to pump. This will lead to higher system pressures especially in colder weather. These greases are unlikely, however, to cause pressures exceeding the design parameters of the system.
3. Grease bases have a fibrous structure and in some cases these can be large enough to prevent it passing through the filter supplied with the Greasemaster II and 3 pumps. This will particularly be the case with Complex base greases and a few simple base greases where the manufacturing process has not fully homogenised the structure. In these cases it is open to the operator to either change greases (recommended), increase the frequency of filter cleaning or to remove the filter gauze. In the latter case it will then be necessary to take extra care when filling.
4. As well as oil and thickener (soap base) greases contain additives to enhance properties. These are unlikely to affect the system with the exception of Graphite which will build up on surfaces and effect tolerances.
5. All greases are subject to the gradual leaching out of oil over a period of time, this can cause blockages to occur within the system. This is not normally going to affect equipment which is in continual use. Where equipment is to be stood down for a period of months it is recommended to operate the system occasionally to move the older grease out of the system. It is also recommended that operators make their last fills with an NGLI grade 1 grease as this will slow the process.

Warranty

MASTERLUBE SYSTEMS LTD. (The Company) guarantees its products to conform to their specifications and to be free from defects therein due to faulty workmanship or materials for a period of twelve (12) months from the date of delivery to the purchaser or from the documented date of installation which shall in no event be more than six (6) calendar months from the date of delivery.

There are no other warranties express or implied including but not limited to the warranties of merchantability and fitness for the particular purpose.

Some states do not permit the limitations of warranties.

The Company shall not be liable for any damages resulting in whole or in part, directly or indirectly, as a result of any misuse, accident, negligence, or improper installation or adjustment.

The Company shall not be bound by or be liable for any affirmation of fact, promise, representation or inducement made by any agent, distributor, or reseller which is not embodied in this agreement.

In no event shall the company be liable for damages, regardless of the form of action, or nature of the claim, exceeding the costs of the products. In no event shall the company be liable for loss of profit, indirect, incidental, special, consequential or other similar damages arising out of the use of the products, even if the company has been advised of special circumstances of the customer or the possibility of such damages.

In any event the customer's sole and exclusive remedy shall be the repair or replacement of the product.

MASTERLUBE SYSTEMS LTD.

UNIT 15, DABBLE DUCK IND. EST.

SHILDON

CO. DURHAM

DL4 2QN

UK

TEL:+44(0)1388 775584

FAX:+44(0)1388778893

WEB: www.bignall.co.uk

